

KWV/KWE Konsolenwinde

Zuglast 250–1.250 daN

Ausstattung und Verarbeitung

- Robuste Ausführung
- Lastdruckbremse
- Offene Bauart
- Hohe Seilkapazität
- korrosionsbeständig

* Optional

- Verzinkte Ausführung
- Edelstahl-Ausführung (1.4301)

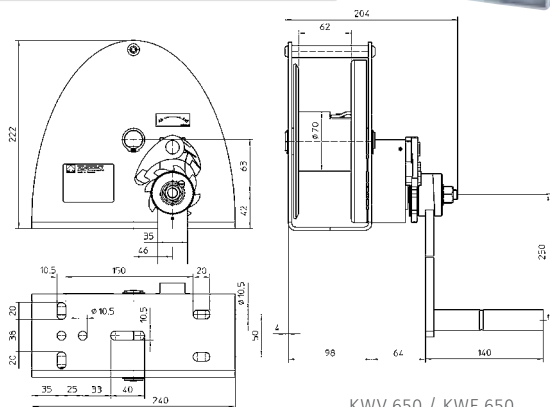

KWV 650 / KWE 650

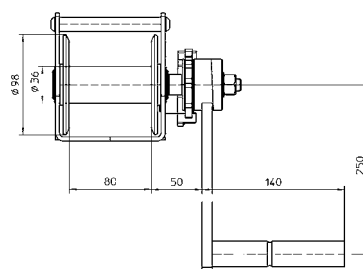

KWV 300 / KWE 250

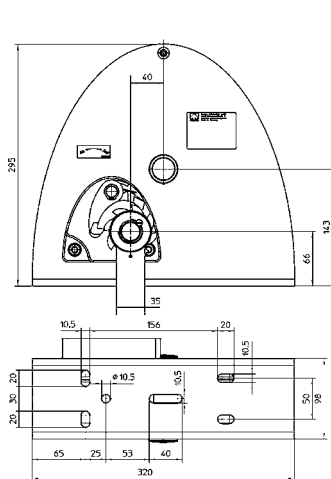

KWV 1250 / KWE 1000

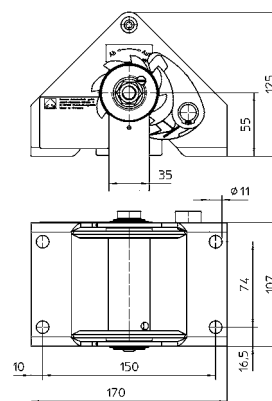
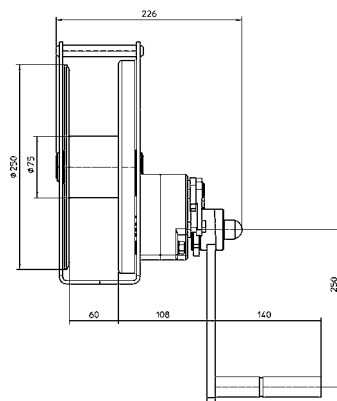

Modell	Zuglast		Befestigung	Material	Seil-Ø	max. Seilaufnahme	Kurbel- druck	Hub je Kurbel- umdrehung	Gewicht	Preis pro Stück
	1. Lage	oberste Lage								(ohne Seil)
	daN	daN							kg	Euro
KWV 300	300	150	Konsole	verzinkt	4	22,0	270	126	4,0	320,00
KWV 650	650	330	Konsole	verzinkt	6	23,0	240	39	9,0	340,00
KWV 1250	1.225	480	Konsole	verzinkt	8	28,5	240	16	16,0	655,00
KWE 250	250	125	Konsole	Edelstahl	4	22,0	220	126	4,0	457,00
KWE 650	650	340	Konsole	Edelstahl	7	16,0	240	39	9,3	674,00
KWE 1000	1.000	390	Konsole	Edelstahl	8	28,5	200	16	16,0	946,00